

UNO SPECS.

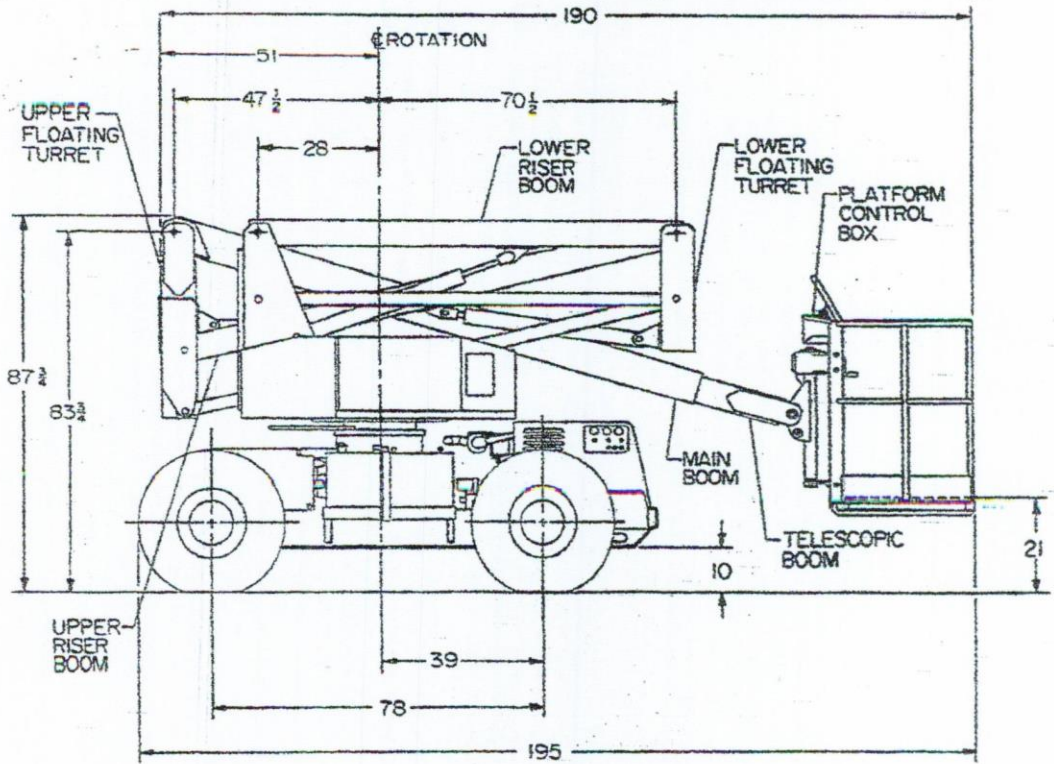

SUN RENTAL CENTER
SE 1105 LATAH
PULLMAN, WA 99163-5409

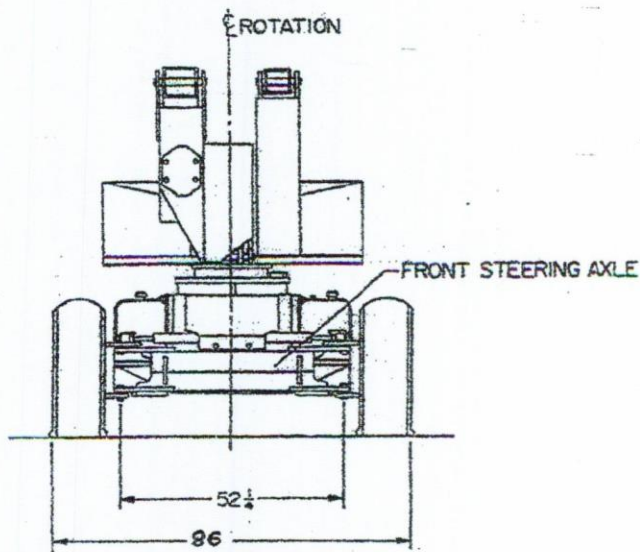

GENERAL DESCRIPTION

MODEL UNO-41D/41G (4x4)

MAXIMUM PLATFORM HEIGHT	40 FEET - 10 INCHES
WORKING HEIGHT - NOMINAL	46 FEET - 10 INCHES
HORIZONTAL REACH	23 FEET - 7 INCHES
PLATFORM SIZE (STANDARD)	30 x 60 INCHES
WEIGHT (APPROXIMATE)	12,500 POUNDS
UNRESTRICTED PLATFORM CAPACITY	500 POUNDS
TRAVEL SPEED	
HIGH	4.5 M.P.H.
MIDDLE	2.75 M.P.H.
LOW	1.33 M.P.H.
TURNING DIAMETER (INSIDE)	13 FEET - 0 INCHES
OVERALL LENGTH (STOWED)	16 FEET - 3 INCHES
OVERALL WIDTH	7 FEET - 2 INCHES
OVERALL HEIGHT - (STOWED)	7 FEET - 4 INCHES
WHEELBASE	78 INCHES
GROUND CLEARANCE	10 INCHES
TIRES	
STANDARD	12 x 16.5, 8 PLY
OPTIONAL (HIGH FLOTATION)	16.5L-16.1
ELECTRICAL SYSTEM	12 VOLT DC
HYDRAULIC SYSTEM MAX. PRESSURE	2,500 PSI

UNIT SERIAL NUMBER _____

The UNO-41D/41G (4x4) "Snorkelift" has been built in so far as we are aware, to conform with OSHA and ANSI Rules and Regulations.

- OSHA Paragraph 1910.67 - Vehicle-mounted Elevating and Rotating Work Platforms - Labor Title 29, C.F.R.
- OSHA Paragraph 1926.556 - Aerial Lifts - Construction Title 29, C.F.R.
- ANSI Standard A92.5-1980 - Boom-Supported Elevating Work Platforms



It is imperative that all owners and users of the UNO (4x4) "Snorkelift" read, understand and conform to these regulations. Ultimate compliance to OSHA regulations is the responsibility of the employer utilizing the equipment.

